



INSTALLATION INSTRUCTIONS

Accessory	Application	Publication No.
SEAT COWL PLATE P/N 08F76-MKN-D50	CB650RA CBR650RA	MII
		Issue Date
		September 2018

Accessory	Application	Publication No.
SEAT COWL PLATE P/N 08F76-MKN-D50	CB650RA CBR650RA	MII
		Issue Date
		September 2018

Accessory	Application	Publication No.
SEAT COWL PLATE P/N 08F76-MKN-D50	CB650RA CBR650RA	MII
		Issue Date
		September 2018

Honda Dealer: Please give a copy of these instructions to your customer.

PARTS LIST

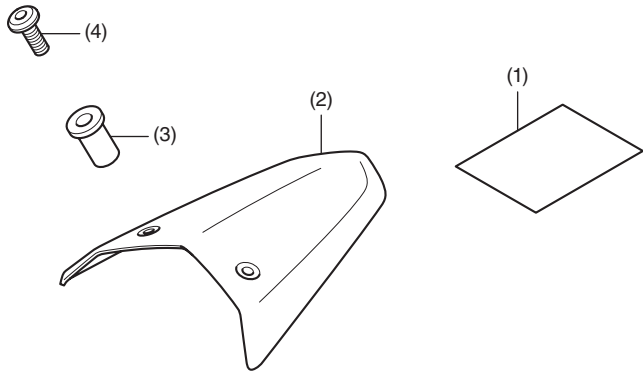

No.	Description	Qty
(1)	URL paper	1
(2)	Seat cowl plate	1
(3)	Well nut	2
(4)	5 mm bolt	2

SEAT COWL Sold separately

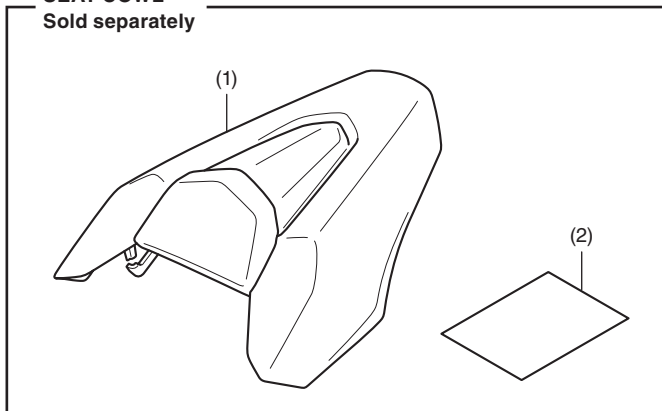

No.	Description	Qty
(1)	Seat cowl	1
(2)	URL paper	1

TOOLS AND SUPPLIES REQUIRED

- Hex wrench (3 mm)
- Electric drill
- Drill bit (10 mm)
- Isopropyl alcohol
- Shop towel
- Torque wrench

TORQUE CHART

Tighten all screws, bolts, and nuts to their specified torque values. Refer to the Service Manual for the torque values of the removed parts.

Item	N·m	kgf·m	lbf·ft
5 mm bolt	0.4	0.04	0.3

INSTALLATION

▲ CAUTION

- To prevent burns, allow the engine, exhaust system, radiator, etc., to cool before installing the accessory.

NOTE:

- Heat the bonding surfaces with a hair dryer if the ambient air temperature is below 70°F (21°C).
- The adhesive reaches full strength in 72 hours. Wait at least 24 hours before riding your motorcycle.

- Remove the seat cowl as shown.

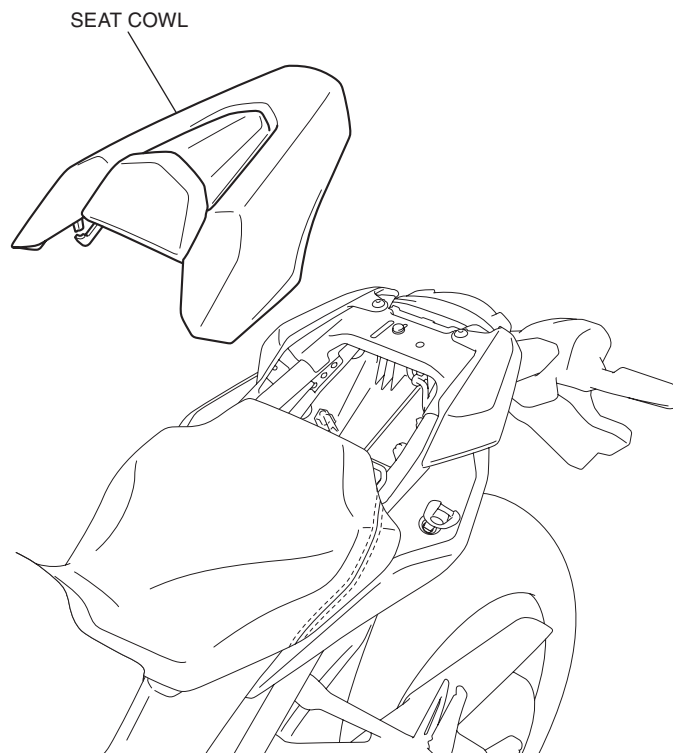

- Drill at the marked points of the seat cowl as shown.
 - Remove the any burrs from the edge of the hole.

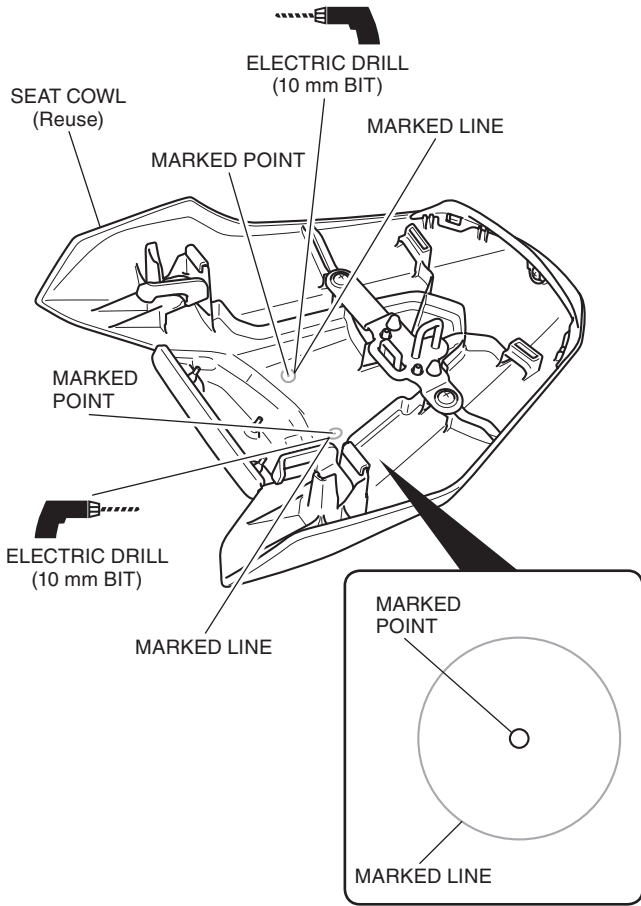

- Install the well nuts as shown.

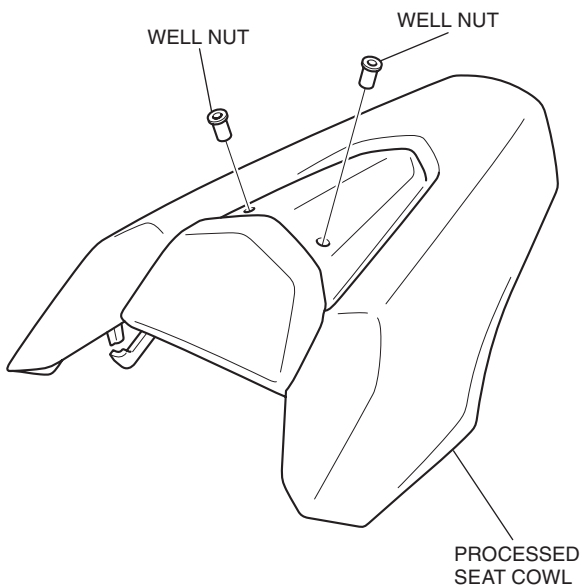

- Clean the surface of the area shown using an isopropyl alcohol.

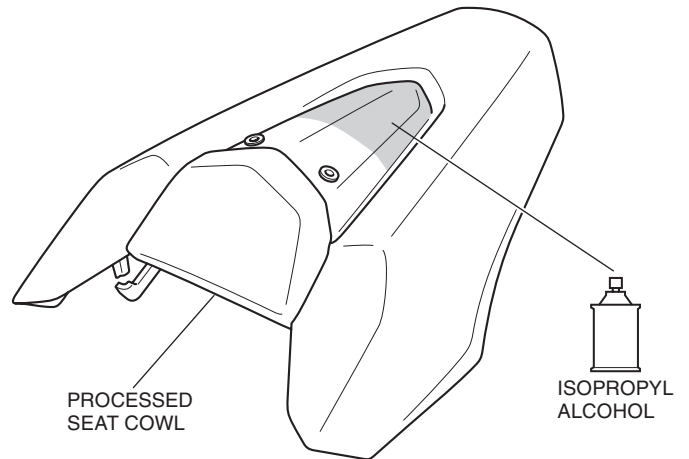

- Remove the adhesive backing as shown.

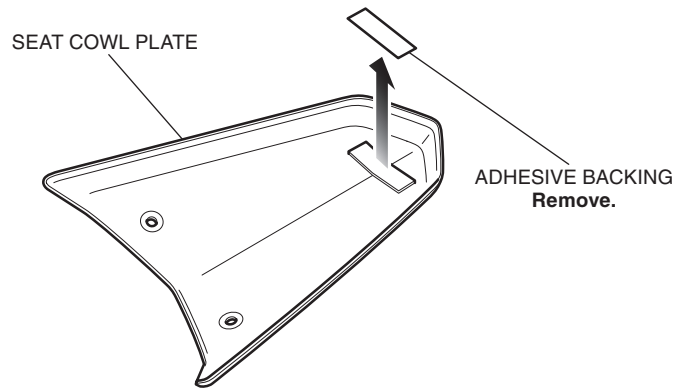

- Install the seat cowl plate as shown.
 - Apply adequate pressure to seat cowl plate.

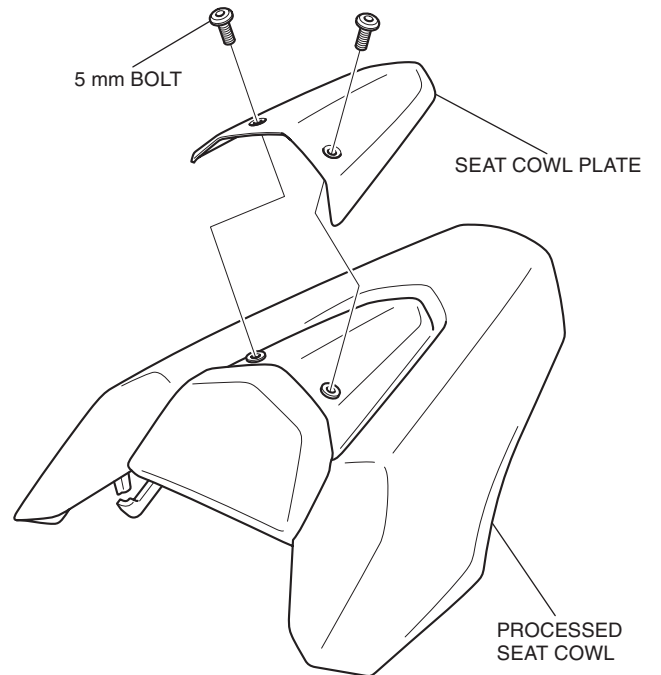

- Install the seat cowl in the reverse order of removal.